

#3E Cattle Fountain

Part # 16743

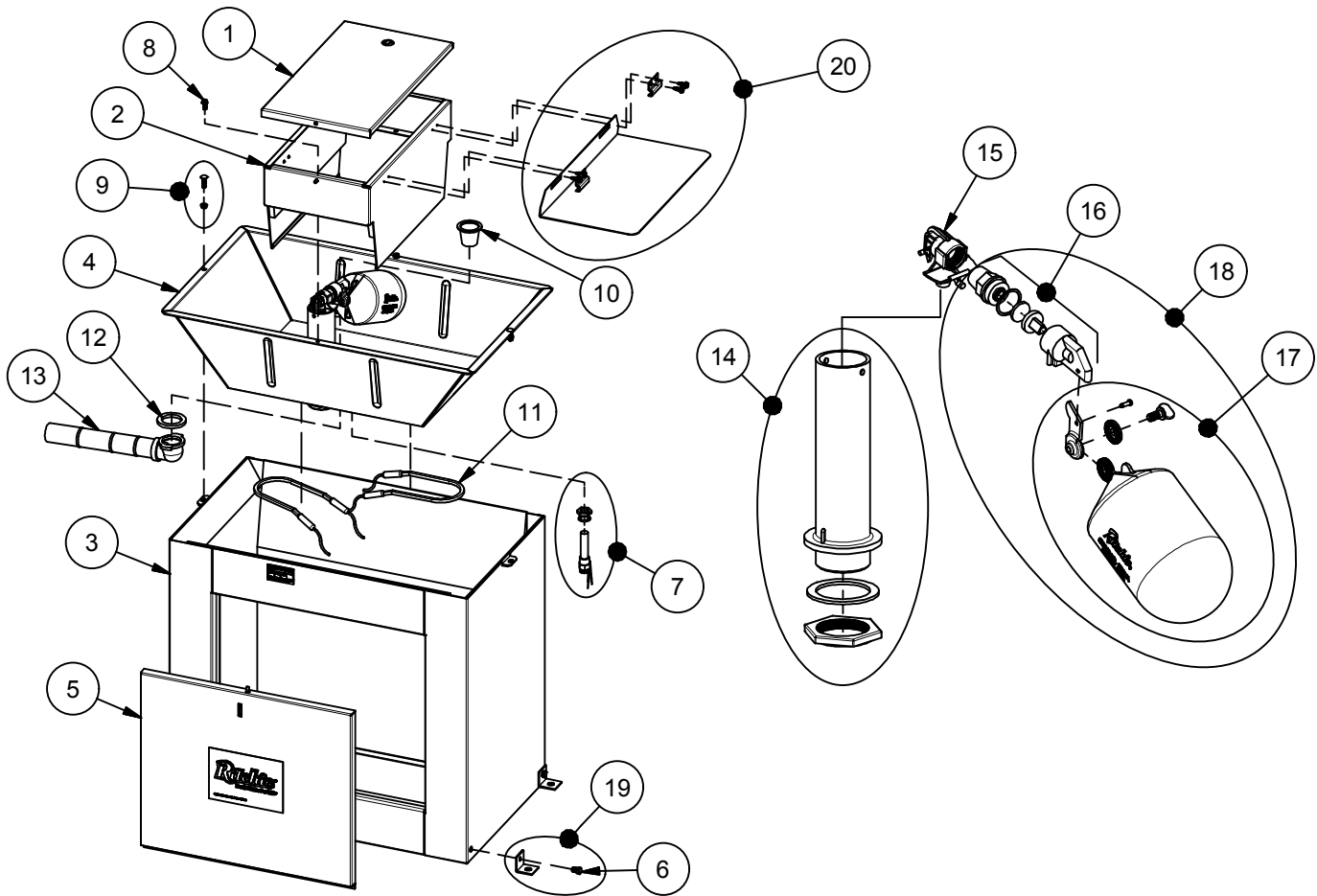

Item	Part #	Description	Qty	Item	Part #	Description	Qty	
1	13373	3E Cover	1	15	11514	Valve Bracket 3/4" pkg	1 pkg	
2	16589	3E Frame	1	16	15377	Green Male Valve 3/4" pkg	1 pkg	
3	12657	3E Casing Pkg	1 pkg	17	18314	Float with Hardware pkg	1 pkg	
4	16744	3E Trough pkg	1 pkg		18313	Hardware for Float pkg	1 pkg	
5	11154	Access Pnl 17"x20" Assembled	1	18	16993	Green Valve & Float pkg	1 pkg	
6	15299	Bolt 3/8"x1/2" SS (4/pkg)	1 pkg	19	13775	Hold Down Angle SS (4/pkg)	1 pkg	
7	16534	Fenwal Thermostat SS pkg	1 pkg	20	16974	Flipper/Hinge (2/pkg) - Optional	1 pkg	
	18320	O-Ring Fenwal (6/pkg)	1 pkg	NS	12583	Valve Supply Line pkg	1 pkg	
	18074	Nut Brass Fenwal (6/pkg)	1 pkg	NS	13830	Cable Htr 120V 48W (1/pkg)	1 pkg	
8	15154	Screw 1/4"x5/8" TC SS (10/pkg)	1 pkg	NS	15634	3E Casing Insulation pkg	1 pkg	
9	18114	Trough Bolt & Nut (5/pkg)	1 pkg	NS	13789	3E Frame Inulation pkg	1 pkg	
10	18628	Drain Plug (2/pkg)	1 pkg	NS	11107	3E Accessory pkg	1 pkg	
11	11419	Heater 120V 250W (1/pkg)	2 pkg		16826	3E 240V		
12	18075	Drain Washer (6/pkg)	1 pkg		NS	11403	Heater 240V 300W (1/pkg)	2 pkg
13	11472	Drain Pipe with Elbow	1	NS	16424	Cable Htr 240V 48W (1/pkg)	1 pkg	
14	16629	Standpipe pkg	1 pkg					