

# Installation Instructions for



## Stall Fount II

*Congratulations, you have just purchased the finest watering fountain on the market. This unit is built to give you excellent service when properly installed and maintained. Please follow instructions carefully. Read and understand all instructions before installing*

## Stall Fount II Installation Instructions

A. **Installation of Ritchie Fountain** - The Stall Fount II - Unheated and the Stall Fount II - Heated are to be corner mounted and are designed to accept the water supply line from below, from above or from behind the fountain through the wall.

B. **Water Supply Line From Underground** - Horizontal underground water line should be sized to account for pressure drop, relating to distance, and placed one foot below the frost line. A one-inch vertical supply pipe is recommended, placed inside of a riser tube. A shut-off valve (as pictured) should be installed under the fountain to allow for servicing. If your facility is cold in the winter, using a Ritchie Thermal Tube in combination with the insulated shroud will provide optimum protection to the vertical supply line against frost and freezing.

C. **Water Supply from Overhead** - Overhead water lines should be sized to account for pressure drop, relating to distance, and placed out of reach of livestock. A one-inch vertical supply pipe is recommended, placed inside of a protective cover. A shut-off valve (as pictured) should be used at the fountain to allow for servicing. If your facility is cold in the winter, additional cold climate protection should be incorporated to protect the vertical supply line against frost and freezing.

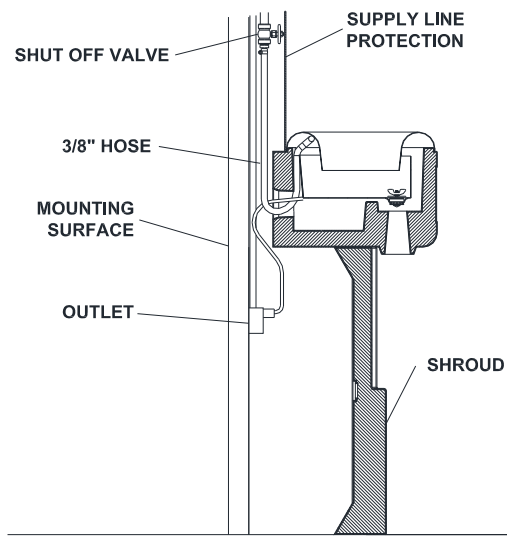
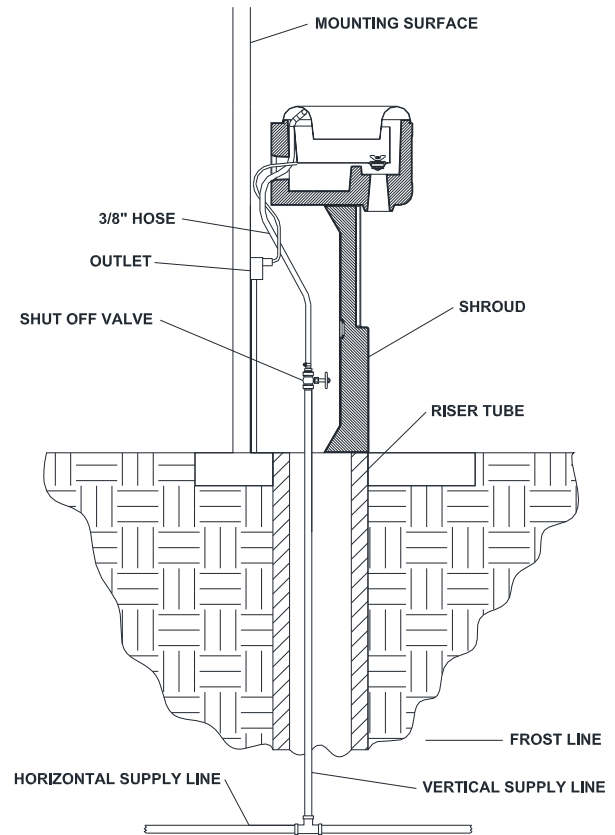

D. **Water Supply Through Wall** - Through wall supply lines should be sized to account for pressure drop, relating to distance, and located to prevent tampering by livestock. A one-inch supply pipe is recommended. A shut-off valve should be located at the fountain to allow for servicing. If your facility is cold in the winter, additional cold climate protection will be required.

E. **Water Hose** - The Stall Fount II comes with a 3/8" rubber hose (30" long) which attaches to the supply pipe with a 3/8" hose barb and hose clamp. When using a riser tube the vertical supply line must be centered in tube below ground to provide an air space between the line and frozen ground outside of tube. Do not surround supply line with insulation, wood or any foreign material. Any foreign material in the tube may cause frost to migrate to supply line causing supply line freezing.

Flush water supply line thoroughly before connection to fountain. Water supplies with foreign material such as sand, rust, etc. may require a filter to keep fountain valve working properly.

**F. Mounting the Fountain** - The stainless steel cover and trough must be removed prior to mounting. The cover can be removed by removing the two slotted screws on the cover. The trough can then be removed by removing the two Phillips headed screws.

**CAUTION: For maximum protection, it is recommended to use the Ritchie Shroud for supply line protection under the unit.**

Mount the unit on the wall at a height appropriate for your animals. If you are using the optional plastic shroud, then use the shroud as a guide for determining the height of the unit. Use of 3/8" carriage bolts or lag screws (not provided), and washers, is recommended. Do not over tighten the screws as damage could occur to the plastic.

After the Stall Fount II is securely mounted to the wall and all supply connections are made you can reinstall the trough with the Phillips headed screws. Do not over tighten the screws as that could result in damage to the plastic base. Install the drain plug in the drain hole from above, pushing the plug into the hole and tightening the wing nut to secure.

**G. Electrical Connection** – **The electrical installation should be made and maintained by qualified electrician conforming to national and local codes.** Electrical Supply wiring can be provided either underground, overhead, or from an inside wall behind fountain. In all cases, a grounded receptacle should be provided for the attached power cord and the wiring should be protected from tampering by the livestock. Connect only to a properly grounded circuit protected by a Ground-Fault Circuit-Interrupter (GFCI). This GFCI protection must be located at the service panel for inspection.

Uncoil the cable heater and attach to water supply line with wire ties (included). Take care not to cross the heated portion of cable over itself along the water line. Do not wrap additional insulation around the heater.

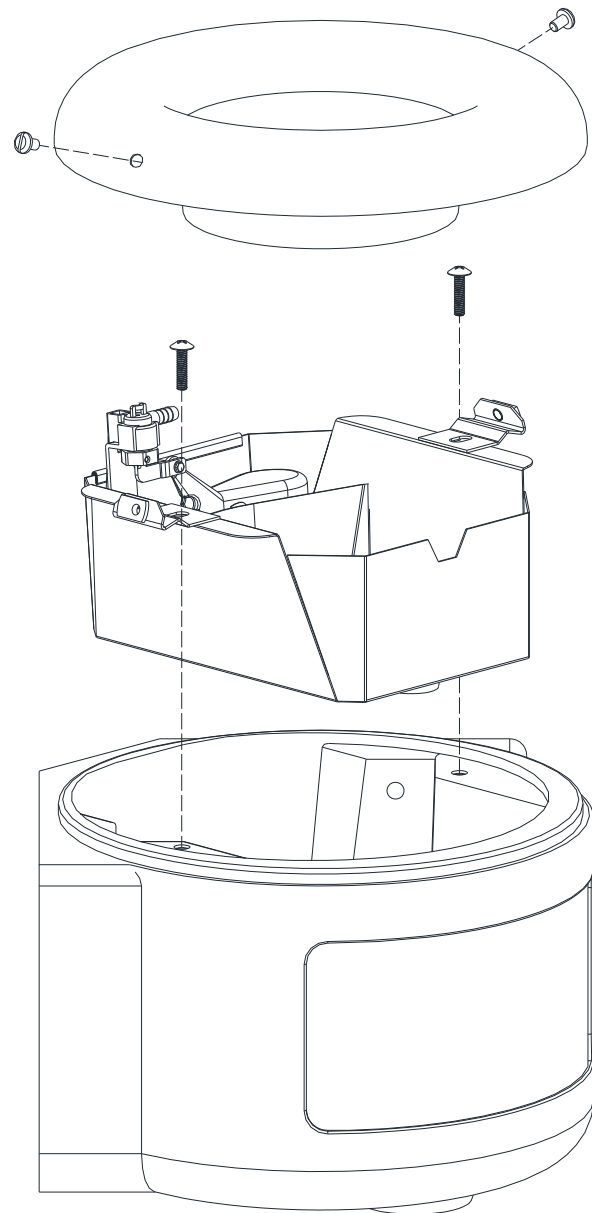

**NOTE: National/Local electrical codes may require livestock waterers installed in feedlots in open feeding area to be grounded by a separate stranded copper grounding conductor or at least No.6 AWG terminating at a point where the branch circuit receives its supply. Check with local inspection authorities.**

**WARNING: This installation must be made and maintained in strict conformity with National/Local plumbing codes and National/Local electrical codes (CSA in Canada). The application of these codes take precedent. Failure to make and maintain all installations properly may result in loss of livestock, personal injury, or death.**

**H. Adjust Water Level** – After the drain plug is installed, turn on water and adjust float to water level mark or until there is approximately 3 inches of water in trough. Float is adjusted by loosening the wing-nut then raising or lowering the float as needed, and then re-tightening the wing-nut. When finished adjusting, reinstall the stainless steel cover with the two slotted screws.

**I. Installing the Shroud (Optional)** – After the plumbing and electrical connections are made, install the shroud under the unit using 3/8" lag screws or bolts. For irregular mounting surfaces, foam tape (included) may be applied to the mounting surfaces to eliminate air gaps. Two inch rigid insulation can be mounted against the stall walls, behind the shroud for maximum supply line protection in severe climates.

**J. Children should be supervised to ensure that they do not play with the appliance** - This appliance is not intended for use by persons (including children) with reduced physical, sensory or mental capabilities or lack of experience and knowledge, unless they have been given supervision or instructions concerning use of the appliance by a person responsible for their safety.

# Stall Fount II - 120V

Part # 18480

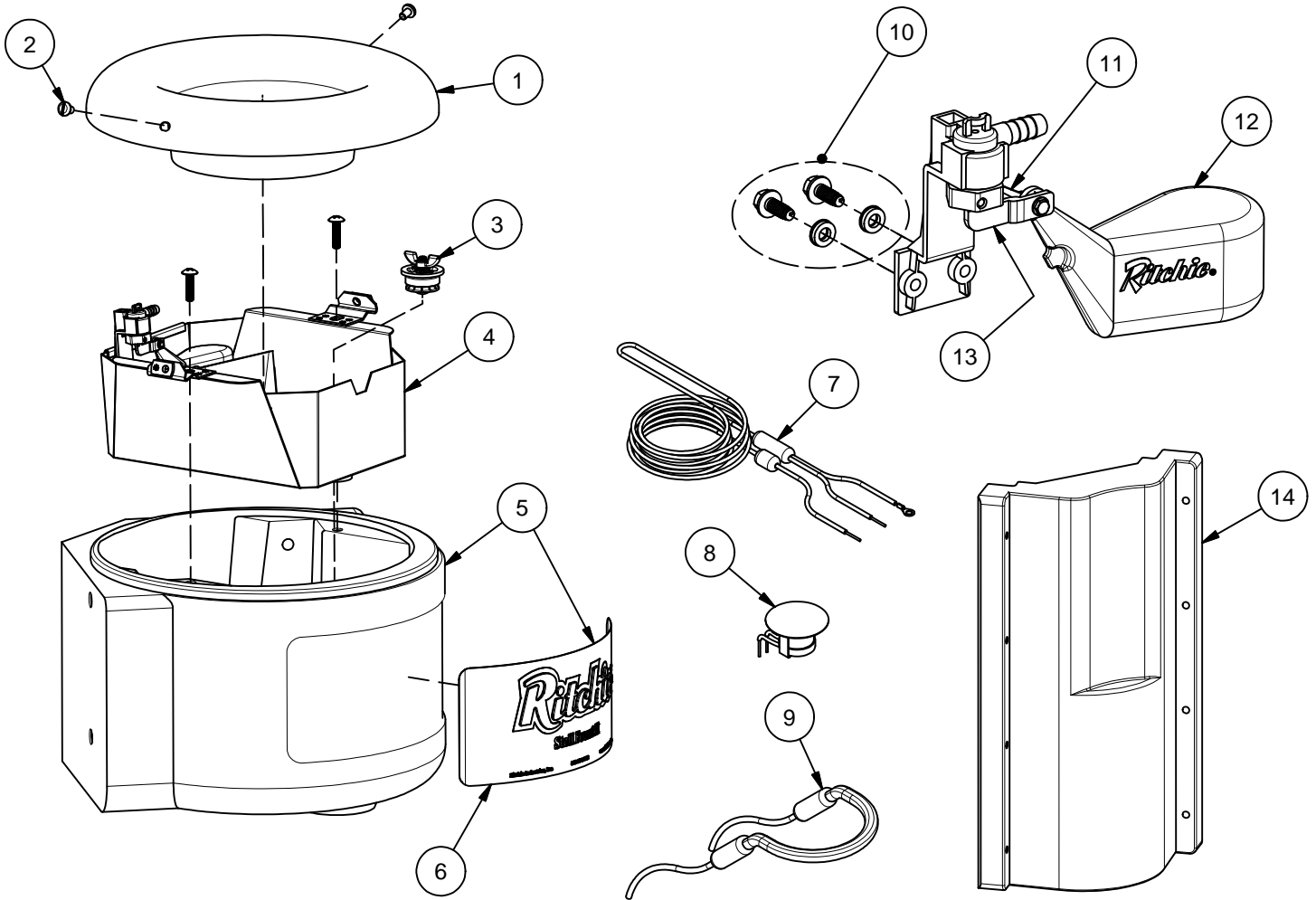

Item	Part #	Description	Qty	Item	Part #	Description	Qty
1	18486	Cover	1	12	18642	Float	1 pkg.
2	18080	Screw Package - Cover (6/pkg)	2	13	13597	Valve Pkg. Green	1 pkg.
3	18643	Drain Plug 1 1/2" Adj	1	14	18491	Shroud 30"	1
4	18477	Trough (120V/240V)	1	NS	18492	Shroud 20"	1
	18487	Trough (No-Heat)	1	NS	18613	Hose Barb Fitting	1 pkg.
5	18482	Stall Fount II Base w/Label	1	NS	15930	Hose Clamp (5/pkg)	1 pkg.
6	18644	Label SFII	1	NS	18488	Complete Accessory Pkg.	1 pkg.
7	13830	Cable Heater 120V 48 Watt	1 pkg.		18490	Stall Fount II - No Heat	
8	11885	Disc Thermostat Pkg.	1 pkg.		18481	Stall Fount II - 240V	
9	14150	Heater 120V 125 Watt	1 pkg.	NS	16664	Heater 240V 200 Watt	1 pkg.
10	18641	Valve Bracket & Screws SF2	1 pkg.	NS	16424	Cable Heater 240V 48 Watt	1 pkg.
11	12576	Wing Nut & Screw	1 pkg.				

## Trouble Shooting

Problem	Solution
Ice in Trough	Check fuses or circuit breakers
	Check heating elements to make sure they are working and hot
	Check voltage after the thermostat to the fountain with and without electrical load.
Cover loose	Decrease the height of the screws.
Supply line freezing	Check that the cable heater is fastened to supply line and is working (hot).
	Check that supply piping is centered in riser tube and that there is air space between riser tube and supply line. Ritchie Thermal Tubes are recommended as they have optimum inside and outside diameter to maximize insulation.
	Check that riser tube is free of water and mud that may freeze.
Valve won't shut off	Check float adjustment. Check for waterlogged float.
	Disassemble valve and check for sand or scale in valve rubber. Also check valve orifice outlets for wear and damage. A screen or filter may be required with sandy or scaly water
	Turn valve rubber over and re-assemble
	Check for excessive water system pressure (greater than 60 psi). May need to use pressure reducer.
Low water flow	Check that valve inlet is not plugged or supply hose is not kinked
	Check system pressure to unit. A severe pressure drop indicates a restriction or undersized supply system.
	Check that shutoff valves are fully open.

## Ritchie Limited Warranty

Effective September 2012

Ritchie Industries, Inc. warrants its products to be free of defective materials and workmanship. Defective part(s) will be repaired or replaced at the option of Ritchie Industries. **This warranty specifically excludes all labor and shipping charges.**

This warranty does not apply to any appearance items, to any product whose exterior has been damaged or defaced, to any product that has been improperly installed, to any product subjected to misuse, abnormal service or handling, and to any products altered or repaired with other than original equipment or manufacturer's parts.

This warranty gives you specific legal rights, and you may also have other rights which may vary from state to state.

All warranty claims must be processed through an Authorized Ritchie Dealer/ Distributor. **Proof of purchase is required. This warranty is not transferable.** The period of warranty begins at original date of purchase as follows:

### Poly Units

#### Base, top and ball closures

10 year limited against manufacturing defect. 100% first five years, then declining 20% per year for the remaining five years.

### Stainless Steel Units

#### Stainless trough and stainless valve chamber frame:

Ten years against manufacturing defect or corrosion. 100% all ten years.

#### Casing and cover:

10 year limited against manufacturing defect. 100% first year, then declining 10% per year for the remaining nine years.

### Component Parts

#### All component parts, such as floats, valves, heating elements:

One year from the date of purchase against manufacturing defect, 100%.

### Hydrants

#### All component parts:

One year from the date of purchase against manufacturing defect, 100%.