

Installation Instructions for



Stall Fount 125

Congratulations, you have just purchased the finest watering fountain on the market. This unit is built to give you excellent service when properly installed and maintained. Please follow instructions carefully. Read and understand all instructions before installing

Stall Fount 125 Installation Instructions

A. **Mounting Fountain** - The Stall fount 125 is designed to accept the water supply line from below the fountain, or from behind the fountain through the wall. **The unit must be installed over a non-combustible surface. The supply line shroud must be in contact with non-combustible floor surface.**

B. **Water Supply Line From Underground** – Horizontal underground water line should be sized to account for pressure drop, relating to distance, and placed well below frost line. A one-inch vertical supply pipe is recommended, placed inside of a riser tile. A shut-off valve (as pictured) should be installed under the fountain to allow for servicing. If your facility is cold in the winter, using a Ritchie Thermal Tube as your riser will provide optimum protection to the vertical supply line against frost and freezing.

The Stall Fount comes with a 3/8" rubber hose (2' long) which attaches to the supply pipe with a 3/8" hose barb (not provided) and hose clamp (not provided). Vertical supply line must be centered in riser tube below ground to provide an air space between the line and frozen ground outside of tube. Do not surround supply line with insulation, wood or any foreign material. Any foreign material in the tube may cause frost to migrate to supply line causing supply line freezing.

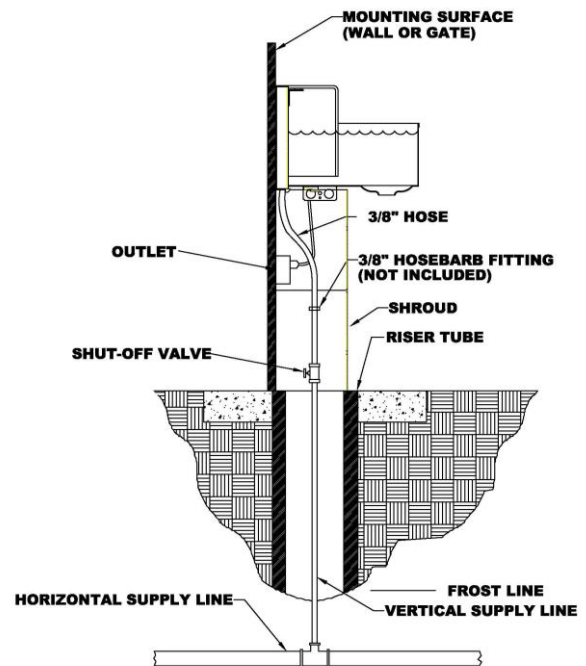

Flush water supply line thoroughly before connection to fountain. Water supplies with foreign material such as sand, rust, etc. may require a filter to keep fountain valve working properly.

Using the adjustable height shroud as a guide (see page 3), mount the unit on the wall at a height appropriate for your animals. Use of 3/8" carriage bolts or lag screws (not provided), and washers, is recommended.

The supply pipe should extend above the shut-off valve to within 12" of the Stall Fount 125.

After Stall Fount is securely mounted to the wall and all supply connections are made, install the drain plug in the drain hole from above, pushing the plug into the hole.

C. **Electrical Connection** – **The electrical installation should be made and maintained by qualified electrician conforming to national and local codes.** Electrical Supply wiring can be provided either underground or from inside wall behind fountain. In all cases a grounded receptacle should be provided for the attached power cord and the wiring should be protected from tampering by the livestock. Connect only to a properly grounded circuit protected by a Ground-Fault Circuit-Interrupter (GFCI). This GFCI protection must be located at the service panel for inspection.

Uncoil cable heater and attach to water supply line with wire ties (included). **Take care not to cross heated portion of cable over itself along the water line.**

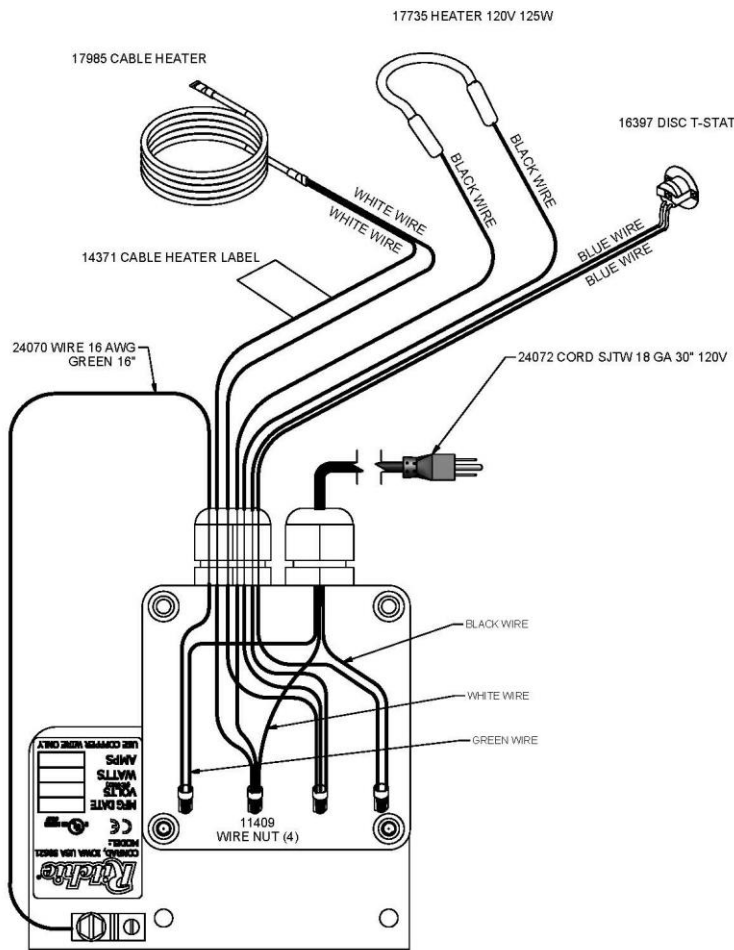

NOTE: National/Local electrical codes may require livestock waterers installed in feedlots in open feeding area to be grounded by a separate stranded copper grounding conductor or at least no.6 AWG terminating at a point where the branch circuit receives its supply. Check with local inspection authorities.

D. Disc Thermostat –The disk thermostat is mounted in a bracket under the trough that allows it to be moved relative to the heater. To ease movement of thermostat turn ¼ turn. To lock in position after adjustment turn ¼ turn back. As the thermostat is moved toward the heater, the water temperature in the trough is lowered. The best location is determined by checking the trough temperature several times during the heating season.

E. Adjust Water Level – Open cover by removing the screw on top. Turn on water and adjust float to water level mark or until there is approximately 3 inches of water in trough. Float is adjusted by loosening the wing-nut then raising or lowering the float as needed, and then re-tightening the wing-nut. When finished adjusting close the cover and reinstall the screw.

F. Installing the Shroud – After the plumbing and electrical connections are made, install the shroud as shown using ¼” screws or bolts. Height of the shroud can be adjusted in 6” increments by removing insulation as needed and moving top shroud down to align next set of holes. Attach ground wire with grounding clip over top edge of top shroud. **Stall fount should always be installed with the shroud in place. The shroud prevents animals from coming in contact with the heater.**

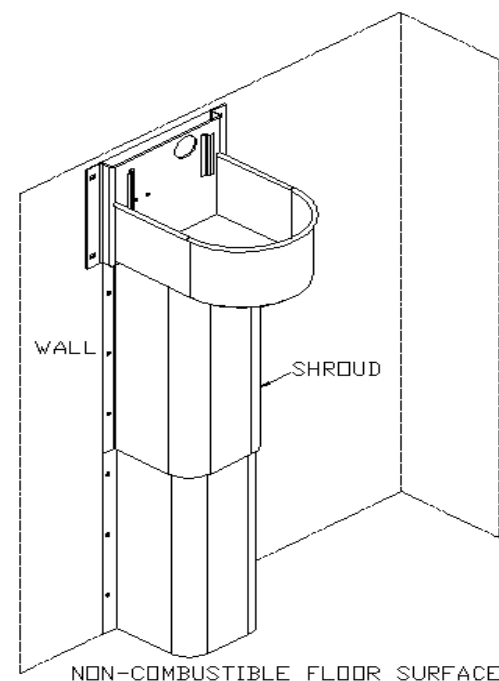

Trouble Shooting

Problem	Solution
Ice in Trough	Check fuses or circuit breakers
	Check all heating elements to make sure they are working and hot
	Check voltage after the thermostat to the fountain with and without electrical load.
Valve freezing	Check that the cable heater is installed properly near valve and fastened to water supply line and is working (hot).
Supply line freezing	Check that the cable heater is fastened to supply line and is working (hot).
	Check that supply piping is centered in riser tube and that there is air space between riser tube and supply line. Ritchie Thermal Tubes are recommended as they have optimum inside and outside diameter to maximize insulation.
	Check that riser tube is free of water and mud that may freeze.
Valve won't shut off	Check float adjustment. Check for waterlogged float, or float rubbing on side of valve compartment.
	Disassemble valve and check for sand or scale in valve rubber. Also check valve orifice outlets for wear and damage. A screen or filter may be required with sandy or scaly water
	Turn valve rubber over and re-assemble
	Check for excessive water system pressure (greater than 60 psi). May need to use pressure reducer.
Low water flow	Check that valve inlet is not plugged or supply hose is not kinked
	Check system pressure to unit. A severe pressure drop indicates a restriction or undersized supply system.
	Check that shutoff valves are fully open.

Ritchie Limited Warranty

Effective September 2012

Ritchie Industries, Inc. warrants its products to be free of defective materials and workmanship. Defective part(s) will be repaired or replaced at the option of Ritchie Industries. **This warranty specifically excludes all labor and shipping charges.**

This warranty does not apply to any appearance items, to any product whose exterior has been damaged or defaced, to any product that has been improperly installed, to any product subjected to misuse, abnormal service or handling, and to any products altered or repaired with other than original equipment or manufacturer's parts.

This warranty gives you specific legal rights, and you may also have other rights which vary from state to state.

All warranty claims must be processed through an Authorized Ritchie Dealer/ Distributor. **Proof of purchase is required. This warranty is not transferrable.** The period of warranty begins at original date of purchase as follows:

Poly Units

Base, top and ball closures

10 year limited against manufacturing defect. 100% first five years, then declining 20% per year for the remaining five years.

Stainless Steel Units

Stainless trough and stainless valve chamber frame:

Ten years against manufacturing defect or corrosion. 100% all ten years.

Casing and cover:

10 year limited against manufacturing defect. 100% first year, then declining 10% per year for the remaining nine years.

Component Parts

All component parts, such as floats, valves, heating elements:

One year from the date of purchase against manufacturing defect, 100%.

Hydrants

All component parts:

One year from the date of purchase against manufacturing defect, 100%.