

Installation Instructions for



Stall Fount

Congratulations, you have just purchased the finest watering fountain on the market. This unit is built to give you excellent service when properly installed and maintained. Please follow instructions carefully. Read and understand all instructions before installing

Stall Fount Installation Instructions

A. **Mounting Fountain** - The Stall Fount is designed to be securely bolted to a wall, or other vertical structure.

B. **Water Supply Line** – A typical installation includes vertical supply line fed from an underground water line, however, the stall fount can also accommodate water supply coming from above, or through the wall behind the fountain. The underground line should be sized to account for pressure drop, relating to distance, and placed at least 1' below frost line. Use of a riser tile surrounding the vertical supply line is recommended. A shut-off valve (as pictured) should be installed under

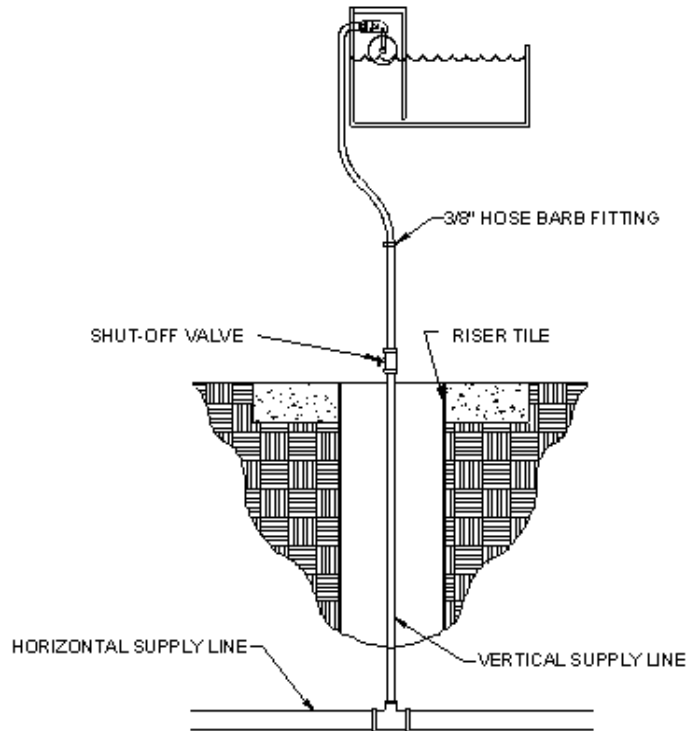

the fountain to allow for servicing. If your facility is cold in the winter, a using a Ritchie Thermal Tube as your riser will provide optimum protection to the vertical supply line against frost and freezing.

The Stall Fount comes with a 3/8" rubber hose (2' long) which attaches to the supply pipe with a 3/8" hose barb (not provided) and hose clamp (not provided). Vertical supply line must be centered in riser tube below ground to provide an air space between the line and frozen ground outside of tube. Do not surround supply line with insulation, wood or any foreign material. Any foreign material in the tube may cause frost to migrate to supply line causing supply line freezing. Flush water supply line thoroughly before connection to fountain. Water supplies with foreign material such as sand, rust, etc. may require a filter to keep fountain valve working properly.

Mount unit on the wall at a height appropriate for your animals (approximately 3' is recommended). Use of 3/8" carriage bolts or lag screws (not provided), and washers, is recommended. The supply pipe should extend above the shut-off valve to within 12" of the Stall Fount. After Stall Fount is securely mounted to the wall and all supply connections are made, install the drain plug in the drain hole from above, pushing the plug into the hole.

C. **Adjust Water Level** – Open cover by removing the screw on top and flipping the cover toward you. Turn on water and adjust float (5) by loosening the wing-nut (6) and raising or lowering the float as needed. Then retighten the wing-nut. 4" water depth is recommended. The arrow inside the trough indicates this level. Close the cover and reinstall the screw.

StallFount

Part # 16871

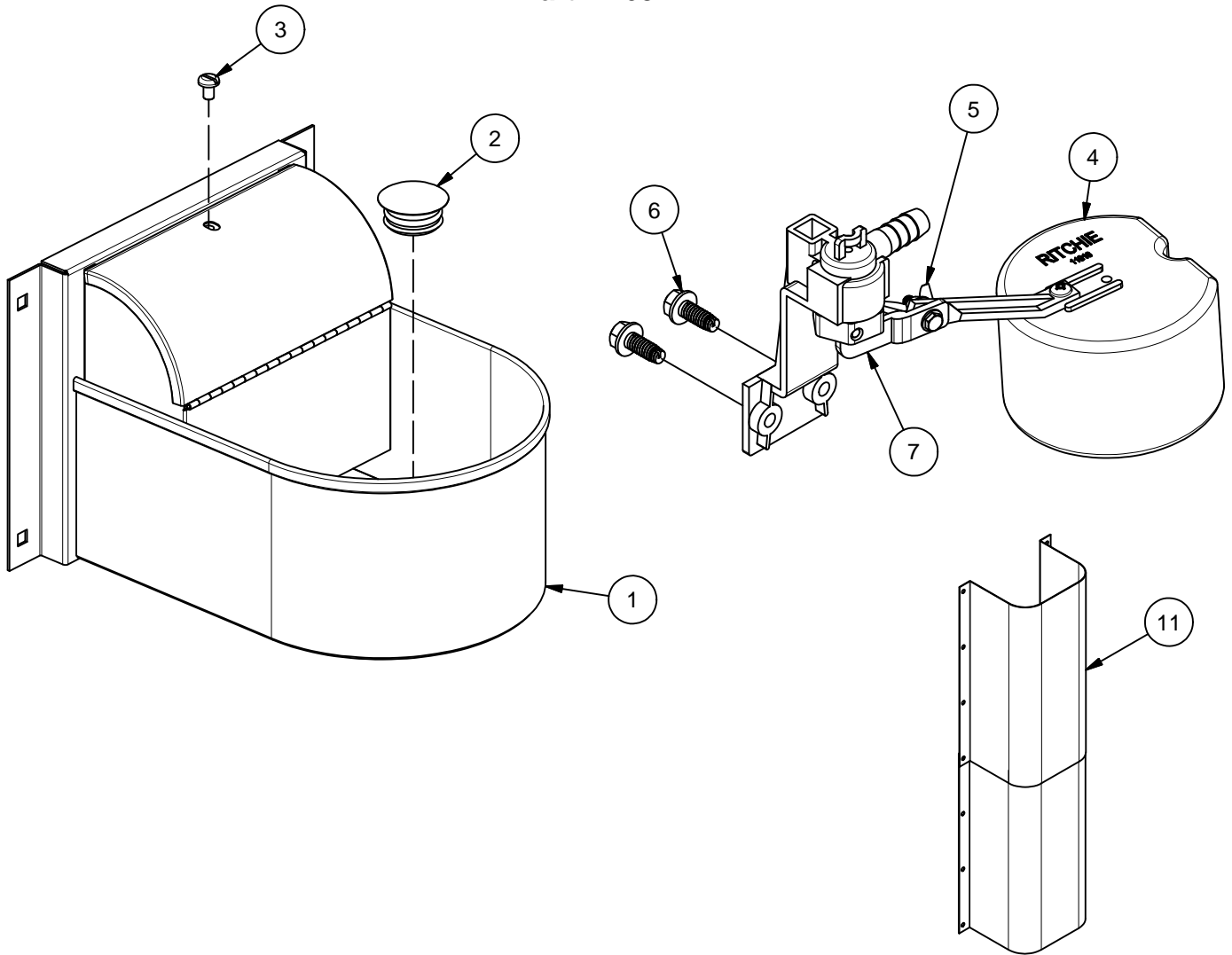

Item	Part #	Description	Qty	Item	Part #	Description	Qty
1	16877	SF Trough Complete	1	6	11515	Valve Bracket w/ screw pkg	1 pkg
2	18221	SF Trough Plug	1	7	13597	Green Valve 1/2" pkg	1 pkg
3	18080	SF Cover Screw	1 pkg	8	18092	Shroud Set Optional.	1 pkg
4	13613	Float with Short Arm pkg	1 pkg	NS	15930	Hose Clamp 7/8" SS (5/pkg)	1 pkg
5	12576	Screw, Star Wshr & Wingnut pkg	1 pkg	NS	18325	SF Accessory pkg	1 pkg

Installation Variations

A stainless steel shroud may be purchased to protect the waterline between the floor and the Ritchie Stall Fount. Part number 18092 includes two sections of shroud, 19 ³/₄ inches long. This part is not required for the non-electric Stall Fount.

Installing the shroud - After the plumbing connections are made, install the optional shroud using 1/4" lag screws or bolts. When more than one section of shroud is used, the total length of the shroud can be adjusted in 6" increments by removing insulation as needed and moving top shroud down to align next set of holes.

Trouble Shooting

Problem	Solution
Valve won't shut off	Check float adjustment. Check for waterlogged float, or float rubbing on side of valve compartment.
	Disassemble valve and check for sand or scale in valve rubber. Also check valve orifice outlets for wear and damage. A screen or filter may be required with sandy or scaly water
	Turn valve rubber over and re-assemble
	Check for excessive water system pressure (greater than 60 psi). May need to use pressure reducer.
Low water flow	Check that valve inlet is not plugged or supply hose is not kinked
	Check system pressure to unit. A severe pressure drop indicates a restriction or undersized supply system.
	Check that shutoff valves are fully open.

Ritchie Limited Warranty

Effective September 2012

Ritchie Industries, Inc. warrants its products to be free of defective materials and workmanship. Defective part(s) will be repaired or replaced at the option of Ritchie Industries. **This warranty specifically excludes all labor and shipping charges.**

This warranty does not apply to any appearance items, to any product whose exterior has been damaged or defaced, to any product that has been improperly installed, to any product subjected to misuse, abnormal service or handling, and to any products altered or repaired with other than original equipment or manufacturer's parts.

This warranty gives you specific legal rights, and you may also have other rights which vary from state to state.

All warranty claims must be processed through an Authorized Ritchie Dealer/ Distributor. **Proof of purchase is required. This warranty is not transferable.** The period of warranty begins at original date of purchase as follows:

Poly Units

Base, top and ball closures

10 year limited against manufacturing defect. 100% first five years, then declining 20% per year for the remaining five years.

Stainless Steel Units

Stainless trough and stainless valve chamber frame:

Ten years against manufacturing defect or corrosion. 100% all ten years.

Casing and cover:

10 year limited against manufacturing defect. 100% first year, then declining 10% per year for the remaining nine years.

Component Parts

All component parts, such as floats, valves, heating elements:

One year from the date of purchase against manufacturing defect, 100%.

Hydrants

All component parts:

One year from the date of purchase against manufacturing defect, 100%.